

CERTIFICATES OF COMPETENCY IN THE MERCHANT NAVY
MARINE ENGINEER OFFICER

STCW 78 as amended MANAGEMENT ENGINEER REG. III/2 (UNLIMITED)

040-36 - ENGINEERING, SYSTEMS AND SHIP'S DRAWINGS

WEDNESDAY, 11 DECEMBER 2019

1315 - 1615 hrs

Materials to be supplied by examination centres

Candidate's examination workbook
Graph paper

Examination Paper Inserts

DRG - 066
DRG - 067
DRG - 068
DRG - 069
DRG - 070

Notes for the guidance of candidates:

1. Examinations administered by SQA on behalf of the Maritime & Coastguard Agency
2. Candidates are required to obtain 50% of the total marks allocated to this paper to gain a pass AND also obtain a minimum 40% in Sections A and B of the paper.
3. Non-programmable calculators may be used.
4. All formulae used must be stated and the method of working and ALL intermediate steps must be made clear in the answer.



ENGINEERING, SYSTEMS AND SHIP'S DRAWINGS

Attempt ALL questions

Marks for each part question are shown in brackets

Section A

1. Piping Systems - DRG 066

- (a) Describe, using drawing references, the three options available for pumping water from the clean bilge holding tank overboard. (3)
- (b) State the tanks the centrifugal separator can take suction from. (3)
- (c) State how often the bilge water is monitored during discharge overboard. (2)
- (d) Describe, using drawing references, how the water level in the intermediate tank can be lowered, when the vessel is in port. Ignore sludge tank and systems not evident on drawing. (2)

2. Mechanical Assembly - DRG 067

- (a) On the indicated boiler feed pump, state what EACH of the following items are, describing their function:
 - (i) item 235; (2)
 - (ii) item 550; (2)
 - (iii) items 570 and 571; (2)
 - (iv) items 530 and 531; (2)
 - (v) item 020. (2)

3. Ship's Construction Drawing - DRG 068

- (a) State the drawing the illustrated section is taken from, outlining how it is used. (2)
- (b) State how the blocks are aligned to prevent distortion of the plate sections. (2)
- (c) State what the numbers 15 to 23 are indicating. (2)
- (d) State, with reasons, what is different around frame numbers 144, 145 and 147, and describe what is done to alleviate the problem. (2)
- (e) State what is indicated regarding the blocks for frames 149 - 156. (2)

4. Hydraulic and Pneumatic System Drawings - DRG 069

- (a) State the different operating pressures evident in the system shown. (2)
- (b) State the operating pressure of the working air receiver, explaining how this can be ascertained from the drawing. (2)
- (c) State the operating pressure the quick closing valves operate at. (2)
- (d) State the air pressure used for clearing of sea chests. (2)
- (e) State the compressors capable of supplying control air. (2)

5. Electrical Power Systems and Control Drawings - DRG 070

- (a) State the identity of the local start and stop buttons. (2)
- (b) State the function of each of the contact sets attached to number 4 contactor. (3)
- (c) State the function of RL1 and RL2. (2)
- (d) Using drawing references, describe the sequence of actions that occur, should the compressor experience low lubricating oil pressure. (3)

Section B

6. Mechanical Assembly - DRG 067

- (a) Describe the most frequent routine maintenance task the illustrated pump requires. (5)
- (b) State the type of seal arrangement used by the pump. (2)
- (c) Describe, using drawing references, the procedure for overhaul of the pump assembly. The overhaul should include replacement of all components subject to wear. (18)

7. Electrical Power Systems and Control Drawings DRG 070

- (a) Using drawing references, describe the sequence of actions that occur, after the compressor start button '35' has been pushed, until it is running on load. (15)
35
- (b) Using drawing references, describe the sequence of actions that occur once the compressor is running on full load. (6)
- (c) Describe the function of breaker 88SH. (4)

DRG.070

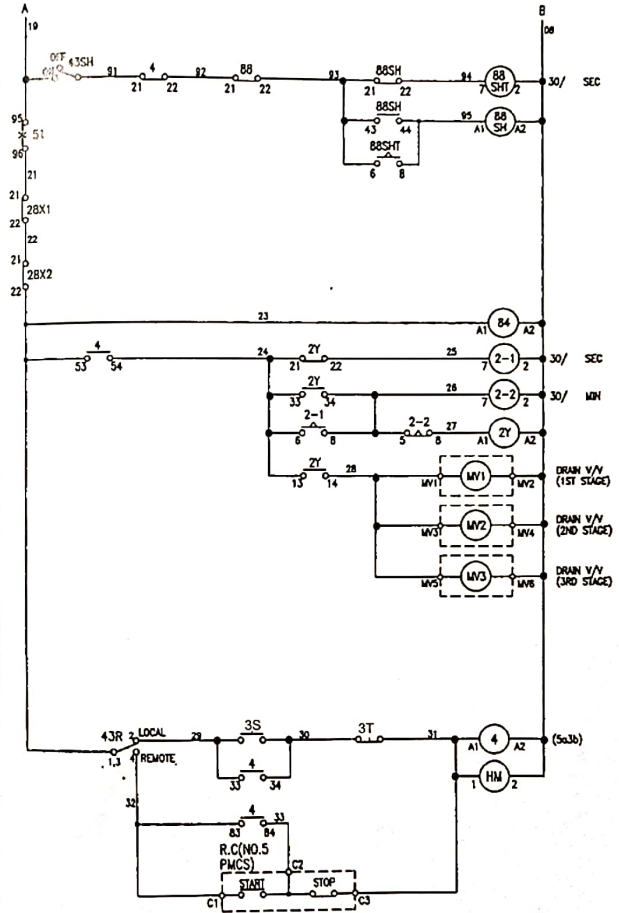
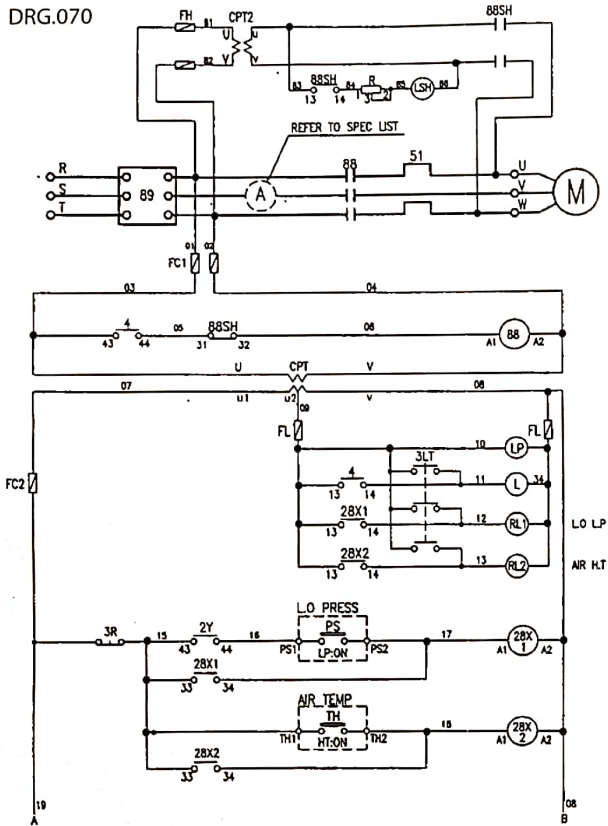

P-LS6-1 NO.1 MAIN AIR COMPRESSOR SD25

HI-1535-SL-S025
A B C D E F

SCHEMATIC DIAGRAM

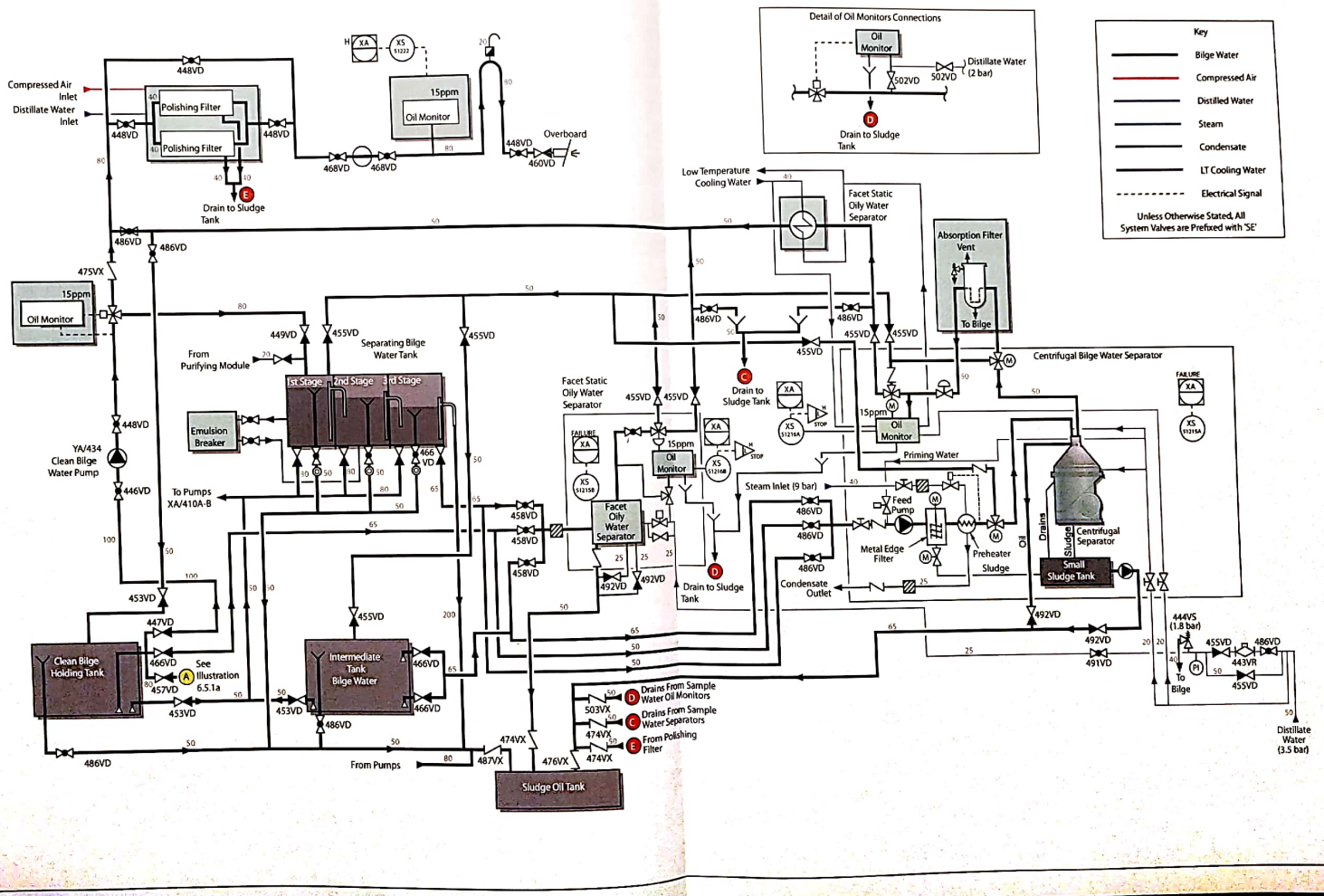

DRG.067

